

Changes to NFPA 70-2005, *National Electrical Code*®

Article 760 and articles referenced by article 760

(Strike-through text is ~~deleted~~ and underlined text is new.)

NFPA 70-2005¹ 760.3 Other Articles.

(A) Spread of Fire or Products of Combustion. Section 300.21. The accessible portion of abandoned fire alarm cables shall ~~not be permitted to remain~~ be removed.

~~760.5~~ 760.7 Access to Electrical Equipment Behind Panels Designed to Allow Access.

Access to electrical equipment shall not be denied by an accumulation of conductors and cables that prevents removal of panels, including suspended ceiling panels.

~~760.6~~ 760.8 Mechanical Execution of Work. Fire alarm circuits shall be installed in a neat workmanlike manner. Cables and conductors installed exposed on the surface of ceilings and sidewalls shall be supported by ~~structural components of the building~~ the building structure in such a manner that the cable or conductors will not be damaged by normal building use. Such cables shall be ~~attached to structural components~~ supported by straps, staples, hangers, or similar fittings designed and installed so as not to damage the cable. The installation shall also conform with 300.4(D).

FPN: One source of information describing industry practices is ANSI/NECA 305-2001, Standard for Fire Alarm System Job Practice.

760.21 NPLFA Circuit Power Source Requirements. The power source of non-power-limited fire alarm circuits shall comply with Chapters 1 through 4, and the output voltage shall not be more than 600 volts, nominal. These circuits shall not be supplied through ground-fault circuit interrupters or arc-fault circuit interrupters.

760.25 NPLFA Circuit Wiring Methods. Installation of non-power-limited fire alarm circuits shall be in accordance with 110.3(B), 300.11(A), 300.15, 300.17, and other appropriate articles of Chapter 3.

300.11 Securing and Supporting.

(A) Secured in Place.

(1) **Fire-Rated Assemblies.** Wiring located within the cavity of a fire-rated floor-ceiling or roof-ceiling assembly shall not be secured to, or supported by, the ceiling assembly, including the ceiling support wires. An independent means of secure support shall be provided and shall be permitted to be attached to the assembly. Where independent support wires are used, they shall be distinguishable by color, tagging, or other effective means from those that are part of the fire-rated design.

300.15 Boxes, Conduit Bodies, or Fittings — Where Required.

~~A box shall be installed at each outlet and switch point for concealed knob-and-tube wiring. Fittings and connectors shall be used only with the special wiring methods for which they are designed and listed. Where the wiring method is conduit, tubing, Type AC cable, Type MC cable, Type MI cable, nonmetallic-sheathed cable, or other cables, a box or conduit body complying with article 314 shall be installed at each conductor splice point, outlet point, switch~~

¹ Reprinted with permission from NFPA. This reprinted material is not the complete and official position of the National Fire Protection Association on the referenced subject, which is represented only by the standard in its entirety.

point, junction point, termination point, or pull point, unless otherwise permitted in 300.15(A) through (M).

(L) Manholes and Handhole Enclosures. Where accessible only to qualified persons, a box or conduit body shall not be required for conductors in manholes or handhole enclosures, except where connecting to electrical equipment. The installation shall comply with the provisions of Part IV of Article 140 for manholes, and 314.30 for handhole enclosures.

760.30 Multiconductor NPLFA Cables. Multiconductor non-power-limited fire alarm cables that meet the requirements of ~~760.34~~ 760.81 shall be permitted to be used on fire alarm circuits operating at 150 volts or less and shall be installed in accordance with 760.30(A) and 760.30(B).

(A) NPLFA Wiring Method.

(3) In Hoistways. In rigid metal conduit, rigid nonmetallic conduit, intermediate metal conduit, liquidtight flexible nonmetallic ~~tubing~~ conduit, or electrical metallic tubing where installed in hoistways.

(B) Applications of Listed NPLFA Cables.

(2) Other Spaces Used for Environmental Air.

Exception No. 3: Type NPLFP-CI cable shall be permitted to be installed to provide a 2-hour circuit integrity rated cable.

(3) Riser.

Exception No. 3: Type NPLFR-CI cable shall be permitted to be installed to provide a 2-hour circuit integrity rated cable.

(4) Other Wiring Within Buildings.

Exception No. 3: Type NPLF-CI cable shall be permitted to be installed to provide a 2-hour circuit integrity rated cable.

760.41 Power Sources for PLFA Circuits. The power source for a power-limited fire alarm circuit shall be as specified in 760.41(A), (B), or (C). These circuits shall not be supplied through ground-fault circuit interrupters or arc-fault circuit interrupters.

760.42 Circuit Marking. The equipment supplying PLFA circuits shall be durably marked where plainly visible to indicate each circuit that is a power-limited fire alarm circuit.

760.52 Wiring Methods and Materials on Load Side of the PLFA Power Source. Fire alarm circuits on the load side of the power source shall be permitted to be installed using wiring methods and materials in accordance with 760.52(A), 760.52(B), or a combination of (A) and (B).

760.52 Wiring Methods and Materials on Load Side of the PLFA Power Source.

(B) PLFA Wiring Methods and Materials.

(3) In Hoistways. In rigid metal conduit, rigid nonmetallic conduit, intermediate metal conduit, or electrical metallic tubing where installed in hoistways.

Exception No. 1: As provided for in 620.21 for elevators and similar equipment.

Exception No. 2: Other wiring methods and materials installed in accordance with the requirements of 760.3 shall be permitted to extend or replace the conductors and cables described in 760.71 and permitted by 760.52(B)

760.56 Installation of Conductors of Different PLFA Circuits, Class 2, Class 3, and Communications Circuits in the Same Cable, Enclosure, or Raceway.

(D) Audio System Circuits and PLFA Circuits. Audio system circuits described in 640.9(C) and installed using Class 2 or Class 3 wiring methods in compliance with 725.54 and 725.61 shall not be permitted to be installed in the same cable or raceway with power-limited conductors or cables.

760.61 Applications of Listed PLFA Cables.

(A) Plenum. Cables installed in ducts, plenums, and other spaces used for environmental air shall be Type FPLP. ~~Abandoned cables shall not be permitted to remain.~~ Types FPLP, FPLR, and FPL cables installed in compliance with 300.22 shall be permitted. Type FPLP-CI cable shall be permitted to be installed to provide a 2-hour circuit integrity rated cable.

(B) Riser. Cables installed in risers shall be as described in either (1), (2), or (3):

(1) Cables installed in vertical runs and penetrating more than one floor, or cables installed in vertical runs in a shaft, shall be Type FPLR. Floor penetrations requiring Type FPLR shall contain only cables suitable for riser or plenum use. ~~Abandoned cables shall not be permitted to remain.~~ Type FPLR-CI cable shall be permitted to be installed to provide a 2-hour circuit integrity rated cable.

(C) Other Wiring Within Buildings. Cables installed in building locations other than those covered in 760.61(A) or 760.61(B) shall be as described in either (1), (2), (3), or (4). Type FPL-CI cable shall be permitted to be installed as described in either (1), (2), (3), or (4) to provide a 2-hour circuit integrity rated cable.

(D) Fire Alarm Cable Substitutions. ~~The use and permitted substitutions for fire alarm cables listed in Table 760.61 shall be considered suitable for the purpose and shall be permitted.~~ Where substitute cables are installed, the wiring requirements of Article 760, Parts I and III shall apply.

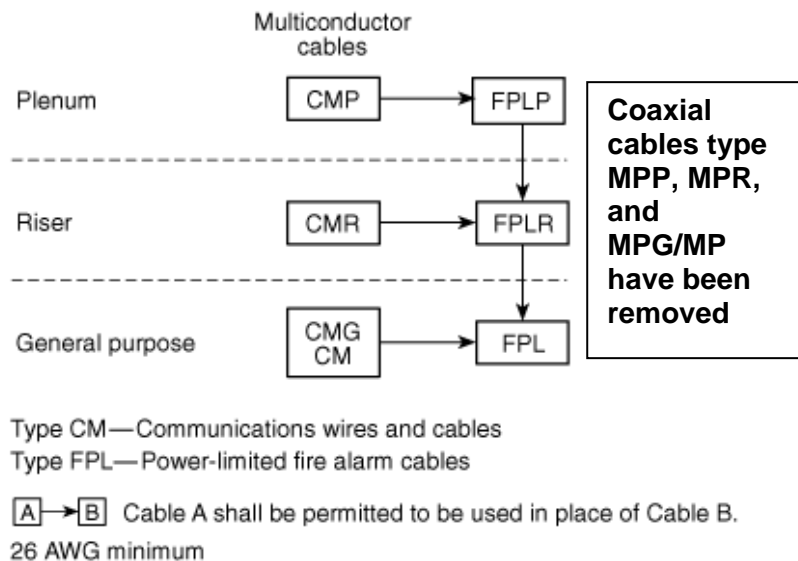

Figure 760.61 Cable Substitution Hierarchy.

Table 760.61 Cable Substitutions

Cable Type	References	Permitted Substitutions
FPLP	760.61(A)	CMP
FPLR	760.61(B)	CMP, FPLP, CMR
FPL	760.61(C)	CMP, FPLP, CMR, FPLR, CMG, CM

Coaxial cables type MPP, MPR, and MPG/MP have been removed from Table 760.61

760.34 760.81 Listing and Marking of NPLFA Cables.

(F) Fire Alarm Circuit Integrity (CI) Cable or Electrical Circuit Protective System. Cables suitable for use in fire alarm systems to ensure used for survivability of critical circuits during a specified time under fire conditions shall be listed as circuit integrity (CI) cable. Cables identified specified in ~~760.34(C)~~ 760.81(C), (D), and (E), that meet the requirements and used for circuit integrity shall have the additional classification using the suffix “-CI” (for example, ~~NPLFP-CI, NPLFR-CI, and NPFL-CI~~). Cables that are part of a listed electrical circuit protective system shall be considered to meet the requirements of survivability.

FPN No. 1: ~~This cable may be used for fire alarm circuits to comply~~ Fire alarm circuit integrity (CI) cable and electrical circuit protective systems may be used for fire alarm circuits to comply with the survivability requirements of ~~NFPA 72-1999, National Fire Alarm Code®, 3-4.2.2.2, 3-84.1.1.4, and 3-8.41.3.3.3(3)~~ NFPA 72®-2002, National Fire Alarm Code®, 6.9.4.3 and 6.9.4.6, that the ~~cable circuit~~ circuit maintain its electrical function during fire conditions for a defined period of time.

760.82 Listing and Marking of PLFA Cables and Insulated Continuous Line-Type Fire Detectors.

(G) Fire Alarm Circuit Integrity (CI) Cable or Electrical Circuit Protective System. Cables suitable for use in fire alarm systems to ensure survivability used for survivability of critical circuits during a specified time under fire conditions shall be listed as circuit integrity (CI) cable. Cables identified specified in ~~760.82(D)~~, 760.71(D), (E), and (F), and (H) that meet the requirements and used for circuit integrity shall have the additional classification using the suffix “-CI” (for example, ~~FPLP-CI, FPLR-CI, and FPL-CI~~). Cables that are part of a listed electrical circuit protective system shall be considered to meet the requirements of survivability.

FPN No. 1: ~~This cable is used for fire alarm circuits as one method of complying~~ Fire alarm circuit integrity (CI) cable and electrical circuit protective systems may be used for fire alarm circuits to comply with the survivability requirements of ~~NFPA 72-1999, National Fire Alarm Code, 3-4.2.2.2, 3-84.1.1.4, and 3-8.4.1.3.3.3(3)~~ NFPA 72®-2002, National Fire Alarm Code®, 6.9.4.3 and 6.9.4.6, that the ~~cable circuit~~ circuit maintain its electrical function during fire conditions for a defined period of time.